



SR3020CT THER SR30200CT

SCHOTTKY BARRIER RECTIFIERS

Reverse Voltage - 20 to 200 Volts Forward Current - 30.0 Ampere

TO-220AB

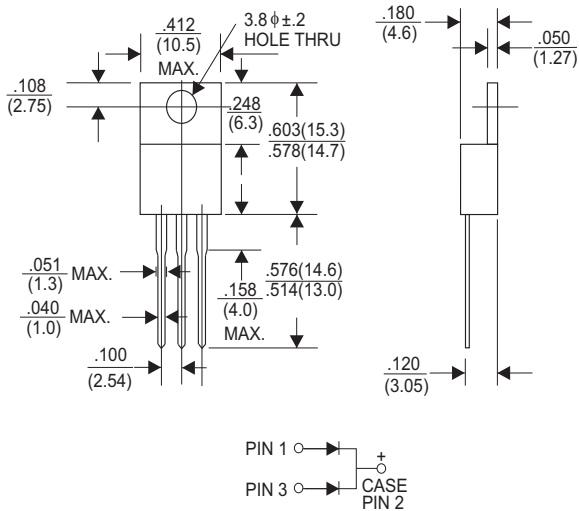

Dimensions in inches and (millimeters)

FEATURES

- * Low forward voltage drop
- * High current capability
- * High reliability
- * High surge current capability
- * Epitaxial construction

MECHANICAL DATA

- * Case: Molded plastic
- * Epoxy: UL 94V-0 rate flame retardant
- * Lead: Axial leads, solderable per MIL-STD-202, method 208 guaranteed
- * Polarity: Color band denotes cathode end
- * Mounting position: Any

MAXIMUM RATINGS AND ELECTRICAL CHARACTERISTICS

Rating 25°C ambient temperature unless otherwise specified.
Single phase half wave, 60Hz, resistive or inductive load.
For capacitive load, derate current by 20%.

TYPE NUMBER	SR30 20CT	SR30 30CT	SR30 40CT	SR30 50CT	SR30 60CT	SR30 80CT	SR30 100CT	SR30 150CT	SR30 200CT	UNITS	
Maximum Recurrent Peak Reverse Voltage	20	30	40	50	60	80	100	150	200	V	
Maximum RMS Voltage	14	21	28	35	42	56	70	105	140	V	
Maximum DC Blocking Voltage	20	30	40	50	60	80	100	150	200	V	
Maximum Average Forward Rectified Current											
See Fig. 1										30.0	A
Peak Forward Surge Current, 8.3 ms single half sine-wave superimposed on rated load (JEDEC method)										300	A
Maximum Instantaneous Forward Voltage at 15.0A	0.55		0.70		0.85		0.95			V	
Maximum DC Reverse Current Ta=25°C										0.05	mA
at Rated DC Blocking Voltage Ta=100°C										10	mA
Typical Junction Capacitance (Note 1)										380	pF
Typical Thermal Resistance RθJA (Note 2)										2.0	°C/W
Operating Temperature Range Tj	-65 — +125				-65 — +150						°C
Storage Temperature Range Tstg										-65 — +150	°C

NOTES:

1. Measured at 1MHz and applied reverse voltage of 4.0V D.C.
2. Thermal Resistance Junction to Ambient Vertical PC Board Mounting 0.5"(12.7mm) Lead Length.

RATING AND CHARACTERISTIC CURVES (SR3020CT THRU SR30200CT)

FIG.1-TYPICAL FORWARD CURRENT DERATING CURVE

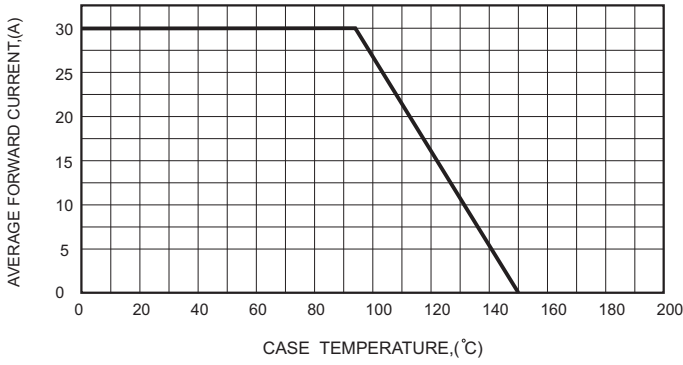

FIG.2-TYPICAL FORWARD CHARACTERISTICS

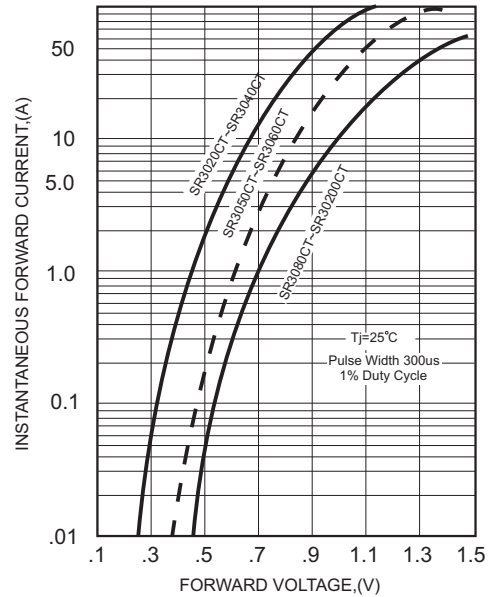

FIG.3-MAXIMUM NON-REPETITIVE FORWARD SURGE CURRENT

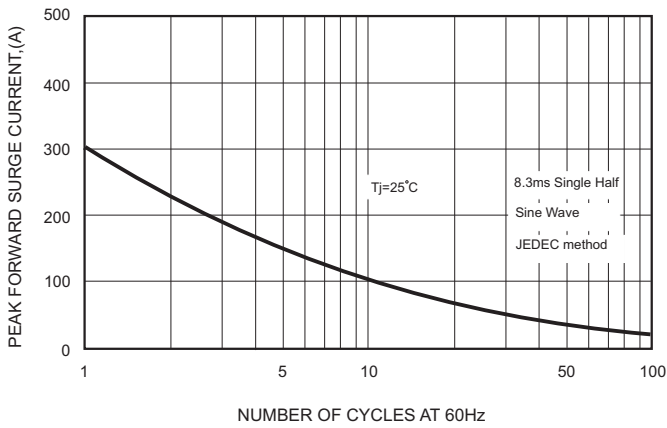

FIG.5 - TYPICAL REVERSE CHARACTERISTICS

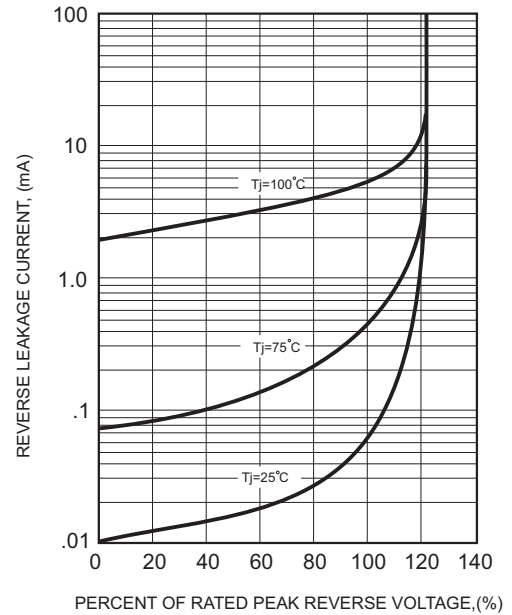

FIG.4-TYPICAL JUNCTION CAPACITANCE

